



# 161 T

G SP

Compact Gravity-fed Soft Serve Model with Heat Treatment for Ice Cream, Sorbet, Frozen Yogurt, Custard, & Plant based recipes



**Performance and Quality** The Carpigiani reputation for the smoothest, creamiest soft serve in the market is proven with this powerful, customizable model. Thanks to the H-O-T system, it is possible to set the desired consistency for creamy Soft Serve Ice Cream, Sorbet, Custard or Frozen Yogurt. Create a unique Soft Serve style by choosing and customizing the shape of your Ice Cream with the optional nozzles.



**Convenience** Hopper prevents mixture separation and maintains consistent refrigerated temperature. Audible Signal alerts when refill is needed. Product is fed from rear of cylinder eliminating need to prime. Least number of components to clean in the industry.



**Savings** The 1.4 QT (1.35 L) Direct expansion cylinder optimizes the refrigeration process, speeding up freezing times and eliminating energy waste. Thanks to the rear chimney it is possible to optimize the installation space and place the machines side by side.



**Safety** TEOREMA guarantees facilitated assistance by providing online monitoring and diagnosis on a tablet, phone or PC wherever you are.



**Hygiene** Standby mode maintains safe product temperatures in the freezing cylinder and mix hopper utilizing minimal energy during idle periods. Our automatic heat treatment system makes it possible to set the automatic heat treatment at a maximum interval of 42 days. \*Always check with your Local Health inspector as cleaning requirements may vary.



\*request the kits from your distributor to maintain your machine hygienically clean.

[carpigiani.com/us](http://carpigiani.com/us)

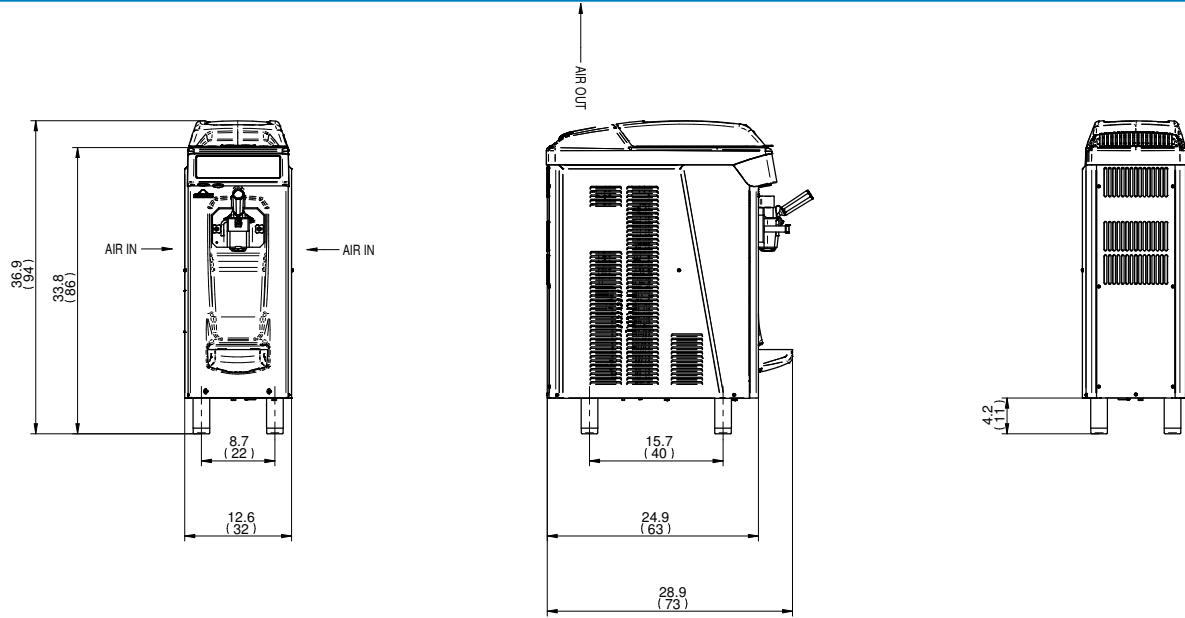

**AIR**

Weights	lbs.	kgs.	
Net	210	95	
Crated	234	107	
Volume	cu. ft.	cu. m.	
Volume	11.30	0.32	
Dimensions	in.	cm.	
Width	12.6	32	
Depth	24.9	63	
Height	36.9	94	
Electrical	Maximum Fuse Size	Minimum Circuit Ampacity	Poles (P) Wires (W)
208-230/60/1 Air	20A	20A	2W+G

## Specifications

### Electrical

A dedicated electrical connection is required. Manufactured to be permanently connected. See the Electrical chart for the proper electrical requirements. Consult your local Carpigiani distributor for cord & receptacle specifications as local codes allow.

### Beater Motor

0,88 HP

### Refrigeration System

R449A

### Air Cooled \*

Minimum clearance: 0" (0 cm) on both side panels and 1" (3 cm) from the rear panel for proper air circulation.

### Hopper Capacity

5.3 quarts (5 liters)

All specifications mentioned must be considered approximate; Carpigiani reserves the right to modify, without notice, all parts deemed necessary. This unit may be manufactured in other electrical characteristics and may have additional regulatory agency approvals, please consult the local Carpigiani Distributor. Check name plate for exact electrical data. \* Room temperature 68 °F (20 °C).

### Bidding Specs

Electrical Volt \_\_\_\_\_ Hz \_\_\_\_\_ Ph \_\_\_\_\_ Neutral  Yes  No Cooling  Air  Water

Options \_\_\_\_\_



738 Gallimore Dairy Road, Suite 113  
High Point, NC - 27265  
Toll free (800) 648 4389



an Ali Group Company



the spirit of excellence